



Pulse Point™ LP-500ST Installation & Operation Manual





Pulse Point™ LP-500ST Installation & Operation Manual

CONTENTS

I. HANDLING AND STORAGE.....	1
Inspection and Handling	
Disposal and Recycling	
Storage	
II. GENERAL SAFETY	2
Authorized Personnel	
Use	
Misuse	
III. PRODUCT DESCRIPTION.....	3
Function	
Applications	
Features	
Technical Specifications	
Figure 1: Temperature Table	
Figure 2: Temperature Graph	
IV. MECHANICAL INSTALLATION	5
Guidelines	
Mounting Considerations	
Figure 3: High/Low Level Location	
Figure 4: Mounting Position	
V. ELECTRICAL INSTALLATION	7
General Safety	
Disconnect Requirements for Permanently Installed Equipment	
Protective Earth Ground	
Electrical Connections	
Figure 5: Wiring	
Figure 6: Fail-Safe Operation	
VI. MAINTENANCE	9
Preventative Maintenance	
VII. TROUBLESHOOTING	9
VIII. DIMENSIONAL DRAWINGS	10

SAFETY SYMBOLS



WARNING:

IDENTIFIES CONDITIONS OR PROCEDURES, WHICH IF NOT FOLLOWED, COULD RESULT IN SERIOUS INJURY.



CAUTION:

IDENTIFIES CONDITIONS OR PROCEDURES, WHICH IF NOT FOLLOWED, COULD RESULT IN SERIOUS DAMAGE OR FAILURE OF THE EQUIPMENT.

Pulse Point™ LP-500ST Installation & Operation Manual



I. HANDLING AND STORAGE

SAVE THESE INSTRUCTIONS

INSPECTION AND HANDLING

Do not dispose of the carton or packing materials.

Each package should be inspected upon receipt for damage that may have occurred due to mishandling during shipping. If the unit is received damaged, notify the carrier or the factory for instructions. Failure to do so may void your warranty. If you have any problems or questions, consult the manufacturer Customer Support at 1-800-778-9242.

DISPOSAL AND RECYCLING

This product can be recycled by specialized companies and must not be disposed of in a municipal collection site. If you do not have the means to dispose of properly, please contact the manufacturer for return and disposal instructions or options.

STORAGE

If the product is not scheduled for immediate installation following delivery, the following steps should be observed:

1. Following inspection, repackage the unit into its original packaging.
2. Select a clean dry site, free of vibration, shock and impact hazards.
3. If storage will be extended longer than 30 days, the unit must be stored at temperatures between -31 to 140° F (-35 to 60° C) in non-condensing atmosphere with humidity less than 98%.

CAUTION: DO NOT STORE A NON-POWERED UNIT OUTDOORS FOR A PROLONGED PERIOD.

II. GENERAL SAFETY

AUTHORIZED PERSONNEL

All instructions described in the document must be performed by authorized and qualified service personnel only. Before installing the unit, please read these instructions and familiarize yourself with the requirements and functions of the device. The required personal protective equipment must always be worn when servicing this device.

USE

The device is solely intended for use as described in this manual. Reliable operation is ensured only if the instrument is used according to the specifications described in this document. For safety and warranty reasons, use of accessory equipment not recommended by the manufacturer or modification of this device is explicitly forbidden. All servicing of this equipment must be performed by qualified service personnel only. This device should be mounted in locations where it will not be subject to tampering by unauthorized personnel.

MISUSE

Improper use or installation of this device may cause the following:

- Personal injury or harm
- Application specific hazards such as vessel overfill
- Damage to the device or system

If any questions or problems arise during installation of this equipment, please contact the manufacturer Customer Support at 800-778-9242.

III. PRODUCT DESCRIPTION

FUNCTION

The LP-500ST is a vibrating rod, level measuring switch suitable for low and high level indication of granules and powders with a minimum density of 3.12 lbs/ft³ (0.05 kg/dm³ density), using vibratory technology.

APPLICATIONS

Unlike radio frequency and capacitance technology sensors, the LP-500ST vibrating probe senses material using a mechanical principle and is therefore not affected by the dielectric constant of the material. This makes it an ideal sensor in plastics, dust, shavings, cement, lime, sand, grain, feed, sugar, etc.

FEATURES

- Universal power supply: AC or DC
- No calibration required
- Adjustable sensitivity
- Fine polished probe

TECHNICAL SPECIFICATIONS

FUNCTIONAL	
Power Requirements	20 to 255 V AC/DC
Power Consumption	≤ 2.5 VA/2 W
Temperature	See Figure 1
Outputs	Main Relay: 8A SPDT @ 250 VAC, AC1
PERFORMANCE	
Pressure Rating	362 psi (25 bar); cable extended 87 psi (6 bar)
Time Delay	Field adjustable; 2 or 5 seconds
Fail Safe	Field selectable, high/low level
Sensitivity	3.12 lbs/ft ³ (0.05 kg/dm ³)
Maximum Particle Size	10mm
PHYSICAL	
Enclosure Material, Rating	Powder Coated Aluminum , IP67, NEMA 6
Conduit Entry	(2) 1/2"NPT; (2) M20 x 1.5
Process Connections	1 1/2"NPT
Maximum Insertion Length (std unit)	8.15 in. (207 mm)
Shipping Weight (standard unit)	4.14 lb (1.88 kg)

Figure 1: Temperature Table

TEMPERATURE DATA	STANDARD AND PIPE EXTENDED VERSION					CABLE EXTENDED VERSION		
					HIGH TEMP			
Medium Temperature Min -22° F (-30° C)	140° F (60° C)	158° F (70° C)	203° F (95° C)	230° F (110° C)	320° F (160° C)	140° F (60° C)	158° F (70° C)	203° F (95° C)
Ambient Temperature Range Min -22° F (-30° C)	140° F (60° C)	122° F (50° C)	140° F (60° C)	122° F (50° C)	95° F (35° C)	140° F (60° C)	122° F (50° C)	140° F (60° C)
Max. Surface Temperature of Process Connection	185° F (85° C)	185° F (85° C)	203° F (95° C)	203° F (95° C)	275° F (135° C)	185° F (85° C)	185° F (85° C)	203° F (95° C)
Max. Surface Temperature	185° F (85° C)	185° F (85° C)	203° F (95° C)	230° F (110° C)	320° F (160° C)	185° F (85° C)	185° F (85° C)	203° F (95° C)

Figure 2: Temperature Graph : Ambient Temperature T_A versus Medium Temperature T_M

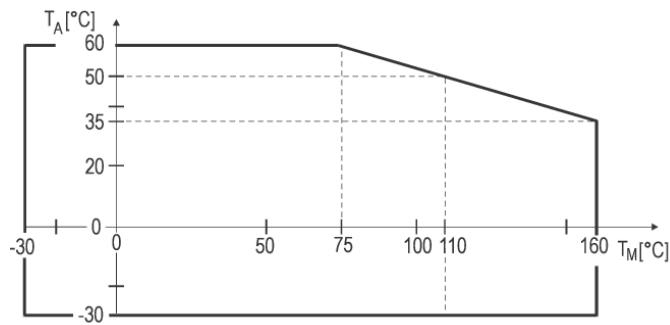

IV. MECHANICAL INSTALLATION



WARNING: REMOVE POWER FROM THE UNIT BEFORE INSTALLING, REMOVING, OR MAKING ADJUSTMENTS

GUIDELINES

The following precautions should be observed when installing and operating the product:

- The installation and wiring of this product must comply with all national, federal, state, municipal and local codes that apply.
- This product is a precision device - handle the device with great care, especially the sensing probe.
- Any impact on the sensing probe may ruin its resonance system.
- A protective shield should be installed if the probe is exposed to falling material or excessive mechanical load.



CAUTION: ATTEMPTING TO TIGHTEN THE LP-500ST BY ROTATING THE HOUSING OR ROD MAY DAMAGE THE UNIT AND VOID THE WARRANTY.

MOUNTING CONSIDERATIONS

Prior to installation, it is advised to check the switching function for proper adjustment on a sample quantity of material. The unit may not work with mediums within the specified density range but having very large size of granules or extremely little friction.

Screw in the device by its hexagon neck. After screwing tight the process connection, the housing can be rotated (max. 300°), to adjust the cable gland to the required position. It might be necessary to install the device at an offset level position relative to the switching level actually required taking into account angle of repose of the material in the silo, see Figure 3.

Figure 3: High/Low Level Location

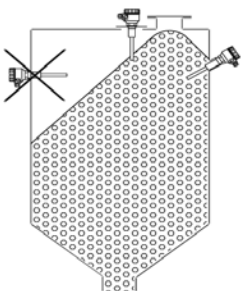

High Level Location

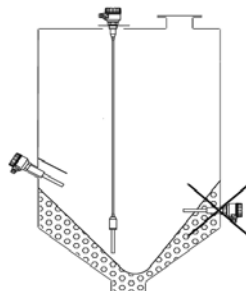

Low Level Location

With powder level detection, device should be installed at an inclination exceeding the angle of repose (or, in case of high level detection vertically), to prevent powder deposition on vibrating rod that might substantially reduce the self-cleaning effect. Also avoid mounting the rod in a recess, see Figure 4.

Figure 4: Mounting Position

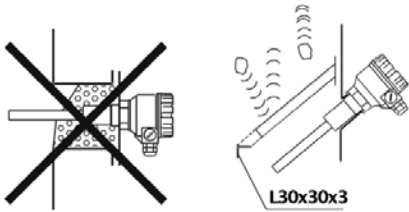

In case of tanks that are likely to be exposed to intense vibrations, necessary provisions shall be made by the customer for damping the vibrations acting on the device (e.g. vibration damping inserts made of rubber have to be applied).

V. ELECTRICAL INSTALLATION



WARNING: VERY HIGH VOLTAGE IS PRESENT ON THE ROD. REMOVE POWER FROM THE UNIT BEFORE INSTALLING, REMOVING, OR MAKING ADJUSTMENTS

GENERAL SAFETY



When using electrical equipment, you should always follow basic safety precautions, including the following:

- The installation and wiring of this product must comply with all national, federal, state, municipal, and local codes that apply.
- Do not modify any factory wiring. Connections should only be made to the terminals described in this section.



CAUTION: ATTEMPTING TO TIGHTEN THE ST-1000 BY ROTATING THE HOUSING OR ROD MAY DAMAGE THE UNIT AND VOID THE WARRANTY

PROTECTIVE EARTH GROUND

To eliminate shock hazards in the unlikely event of an internal insulation breakdown, the unit is provided with a “protective earth” () lead which must be connected to earth ground. In addition, the input power ground lead must be connected to the “protective earth” () terminal provided. Wire sizes must be selected such that it can safely carry the sum total of all circuits’ maximum amperage.

ELECTRICAL CONNECTIONS

Note: The LP-500ST model can be operated from 20-255 V AC/DC and provides reverse polarity protection in the event of a wiring error.

1. Remove the top cover of the housing to access the connection terminals and adjusting switches.
2. Do not remove the wire form terminal pin 1, see Figure 5, because it is an internal connection. For grounding the unit, use the PE grounding screw terminal PE.
3. After proper installation and the electrical connection, established the device is ready for operation. The switched-on state is indicated by the lighting of the LED.

The DENSITY (switch A) switch is to be set in accordance with the density of the material:

- LOW position, recommended for loose and light materials with density below 3.12 lbs/ft³ (0.05 kg/dm³) represents small energy and amplitude of vibration as well as great sensitivity of detection.
- HIGH position, recommended for (thick and heavy) materials with density over 6.24 lbs/ft³ (0.1 kg/dm³) represents vibration with great energy and amplitude and small sensitivity of detection

The instrument may not switch correctly in mediums with density less than 3.12 lbs/ft³ (0.05 kg/dm³) or with very small internal friction.

To obtain FAIL SAFE alarm (switch C), use the de-energized or open state of the output as an alarm, thus a power breakdown will also be considered as alarm, see Figure 6.

The delay (switch B) is to be selected to comply with requirements of the process control technology the units are used for.

Figure 5.
Wiring of relay output version

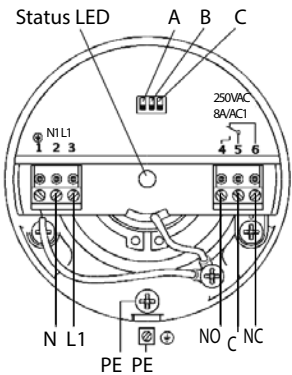

Wiring of optional coupled sink input to solid state output version supplied from an AC line

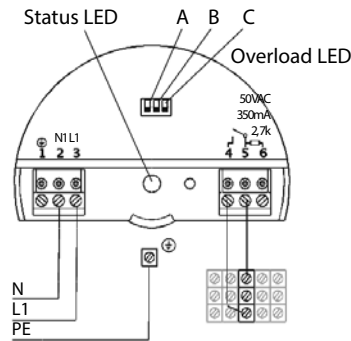

Wiring of a logical voltage input to a solid state output version supplied from an AC line

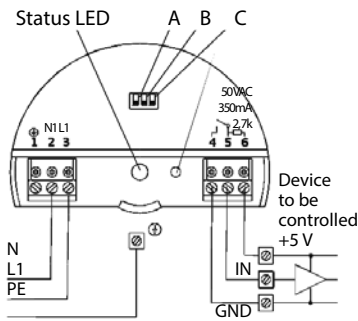

Wiring of a load to a solid state output version supplied from an AC line

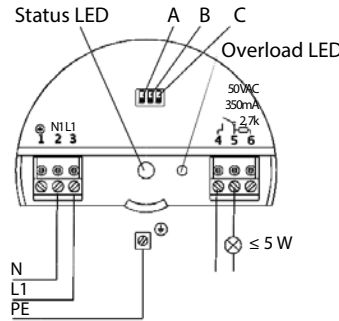

Figure 6. Fail-Safe Operation

Power	Probe	Fail Safe Mode	LED	Relay	Solid State Output
On	Not Vibrating (Covered)	Low	Green	Energized	On
		High	Red	De-Energized	Off
	Vibrating (Free)	Low	Red	Energized	Off
		High	Green	Energized	On
Fails		Low or High	Not Lit	De-Energized	Off

VI. MAINTENANCE

PREVENTATIVE MAINTENANCE

The LP-500ST model does not require maintenance on a regular basis. In some instances, however, the vibrating section may need a cleaning from deposited material. This must be carried out gently, without harming the vibrating section of the vibrating rod.

VII. TROUBLESHOOTING

Contact your local factory representative if additional assistance is needed. Please provide the following information:

- Model number
- Date of Purchase
- Application information (type of material, mounting configuration, etc.)
- Description of problem

If your local representative is unable to determine the cause of difficulty, you will be referred to a factory engineer. Equipment shipped back to the factory without proper authorization will be refused and returned at the shipper's expense.

VIII. DIMENSIONAL DRAWINGS

Values in inches (mm)

Standard

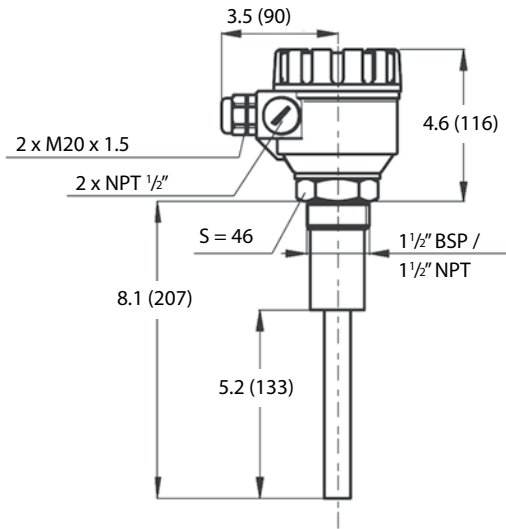

Pipe Extension

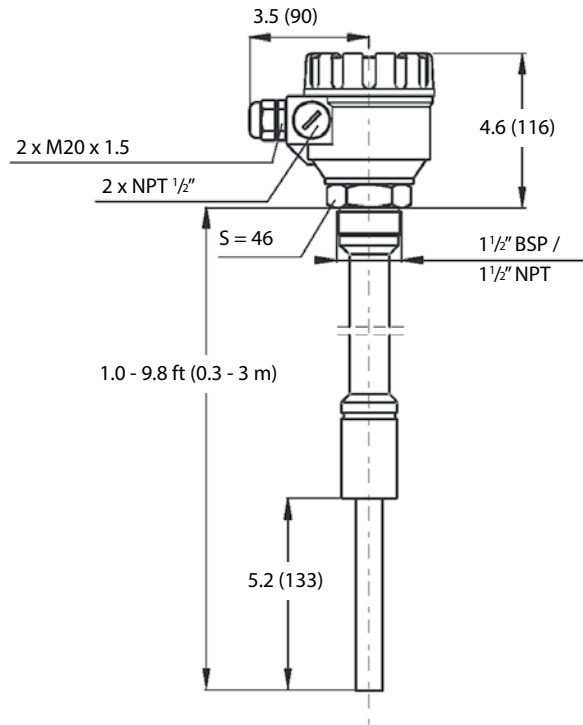

Cable Extension

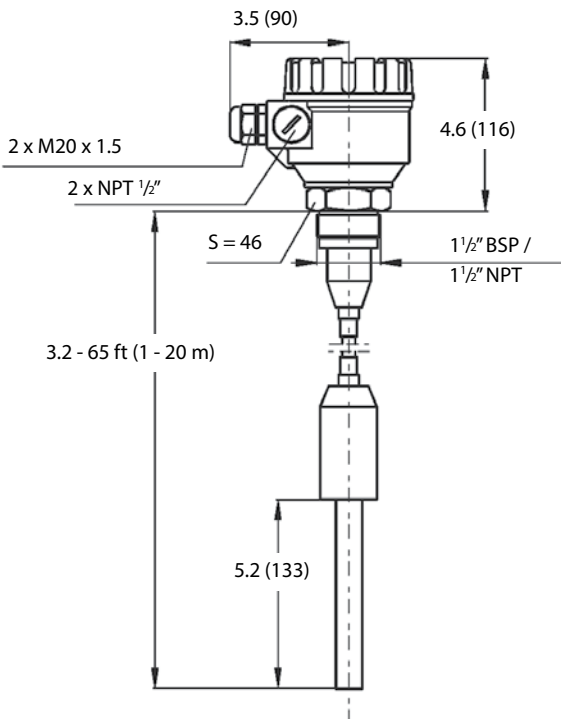



150 Venture Boulevard
Spartanburg, SC 29306
Tel: (800) 778-9242
Fax: (864) 574-8063
sales@bindicator.com
www.bindicator.com

venture
MEASUREMENT

2015 All rights reserved.
All data subject to change without notice.

STS180212 Rev C